

JIBBI

iapa
International
Awards for
Powered
Access
2019
Product of the year

PATENT PENDING

1250 EVO-RT



CRAWLER TELESCOPIC BOOM

ALMACRAWLER 

JIBBI 1250 EVO-RT

Ang JIBBI ay ang bagong crawler telescopic boom ng AlmaCrawler.

JIBBI is the new crawler telescopic boom by AlmaCrawler.

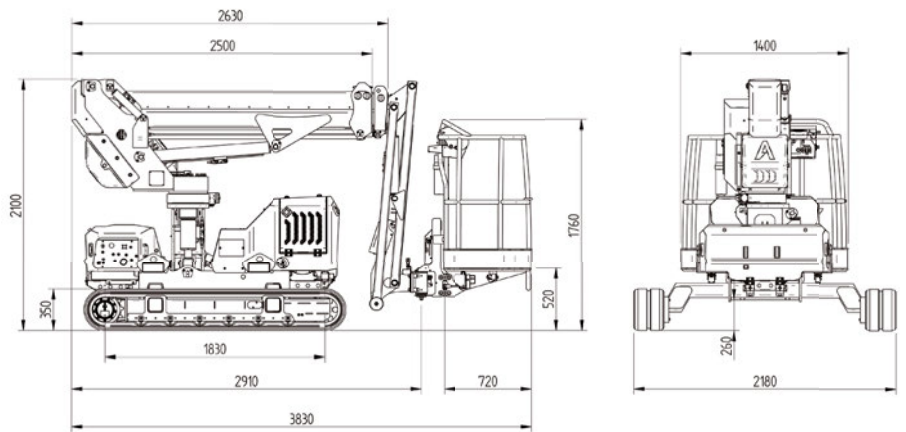

Patent nakabinbing mga makabagong ideya

**Bagong Dynamic Work Performance (DWP ni Almac)
Undercarriage na isinama ng bagong Safe-lock System**

**Patent pending innovations
New Dynamic Work Performance (DWP by Almac)
Undercarriage integrated by new Safe-lock System**



Cable remote console sa pamamagitan ng AUTECH

Cable remote console by AUTECH

Mga Tampok Features

- Yanmar Diesel Engine, 3 Silindro (14,1kW - 19,2 HP)
- 220° Slewing singsing pag ikot
- Basket rotation kit +/- 70°
- Integrated Drive System (gamit ang solong joystick)
- Yanmar Diesel Engine, 3 Cylinders (14,1kW - 19,2 HP)
- 220° Slewing ring rotation
- Basket rotation kit +/- 70°
- Integrated Drive System (using single joystick)

Ultrasonic Anti banggaan System

Ultrasonic Anti-collision System

Automatic & Dynamic Levelling Pro-Active Levelling

**Hinahalong slope leveling
Mixed slope levelling**



Teknikal na data

JIBBI 1250 EVO-RT

Technical data

Max taas ng pagtatrabaho	12,3 m	Max working height
Max taas na sahig ng basket	10,3 m	Max height basket floor
Makina maximum na taas ng paglalakbay	8,1 m	Moving height
Max outreach (mag-load ng 80 kg)	7,0 m	Max outreach (load 80 kg)
Max outreach (mag-load ng 230 kg)	5,4 m	Max outreach (load 230 kg)
Anggulo ng pag-ikot	+/-110°	Rotation angle
Laki ng basket	1,4 x 0,7 m	Basket size
Anggulo ng pag-ikot ng basket	+/- 70°	Basket rotation angle
Max kapasidad ng basket	230 kg	Max basket capacity
Haba sa stowed posisyon	3,8 m	Length in stowed position
Kapad	2,18 m	Width
Min taas sa stowed position	2,10 m	Min height in stowed position
Pag-level ng longitudinal	+/- 15°	Longitudinal leveling
Pag-level ng lateral	+/- 15°	Lateral leveling
Max kakayahang pang-grade	25°	Max gradeability
Max side kakayahang pang-grade	25°	Max side gradeability
Bilis ng drive (mabilis)	2,5 km/h	Drive speed (fast)
Bilis ng seguridad	0,3 km/h	Security speed

Mga Timbang

Weights

Pag-load ng trapiko	3,87 kN/m ²	Traffic load
Kabuuang timbang	2860 kg	Total weight

Lakas

Power

3TNM68 -AS Yanmar engine (diesel)	14 kW - 19,2 Hp	3TNM68 -AS Yanmar engine (diesel)
-----------------------------------	-----------------	-----------------------------------

Kagamitan kapag hiniling

Extras - On Demand

Hindi nagmamarka ng mga track	-	Non-marking tracks
Kontrol ng remote sa radyo	-	Radio remote control
Arctic pampadulas para sa malamig na klima	-	Arctic lubricant for cold climate



JIBBI 1250 EVO-RT

12.2m	230kg	19.2Hp	$\pm 15^\circ$	2.5 km/h	$\pm 15^\circ$
MAX W.H.	CAPACITY	POWER	LONG. LEVEL.	SPEED	LATER. LEVEL.

- 80 kg
- 140 kg
- 230 kg

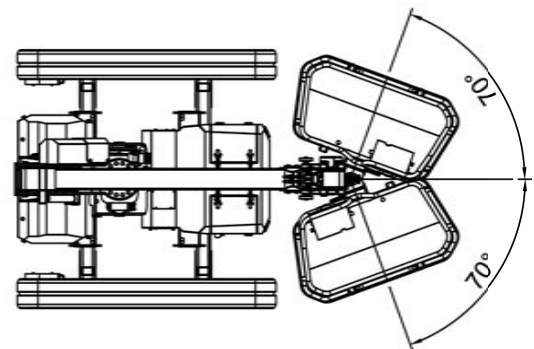
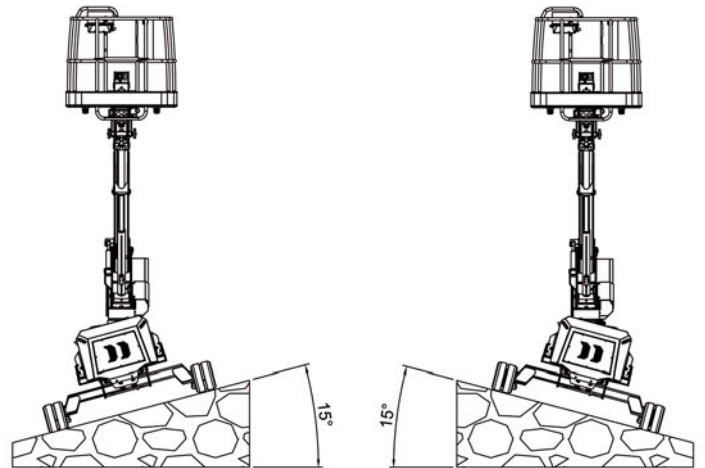
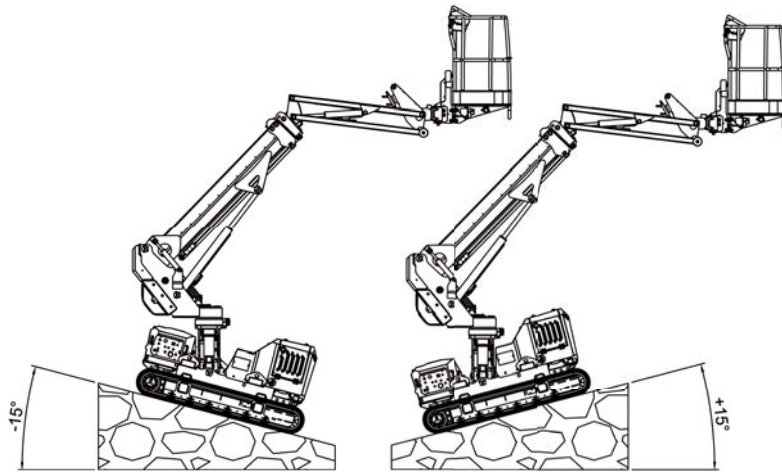
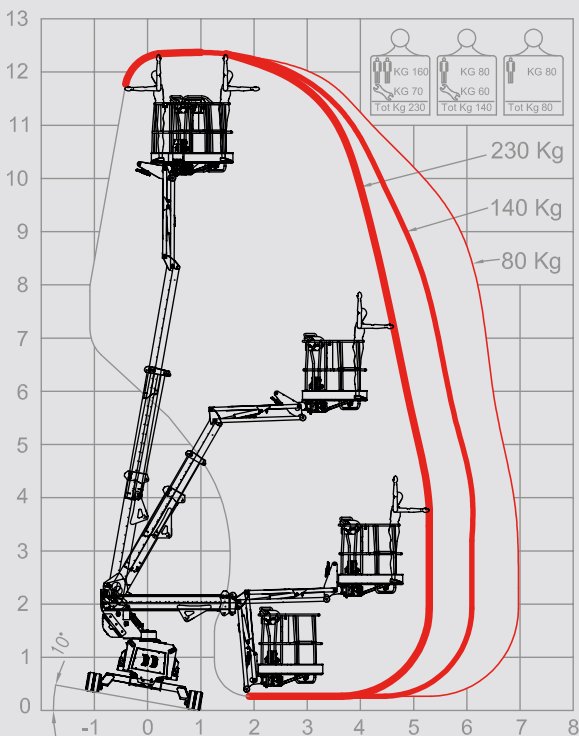
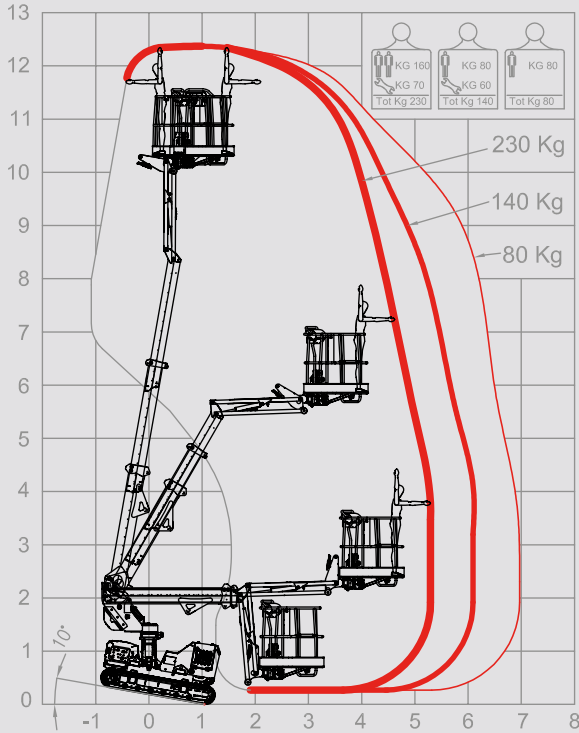

Via Caduti sul Lavoro 1
46019 Viadana (MN) - ITALY
+39 0375 83 35 27
info@almac-italia.com

MAYON MACHINERY RENTRADE, INC
3rd Floor P & J Building, Lot 32, Blk. 69 M. Roxas
Street, Corner Bayani Road AFPOVALI Phase 4, Fort
Bonifacio, Taguig City, Philippines
+ 63 (2) 8776 0254 | sales@mayonmachinery.co

ALMACRAWLER

ALL DATA REPORTED IN THIS CATALOGUE ARE NOT BINDING. ALMAC SRL RESERVES THE RIGHT TO CHANGE SPECIFICATIONS WITHOUT PRIOR NOTICE.