

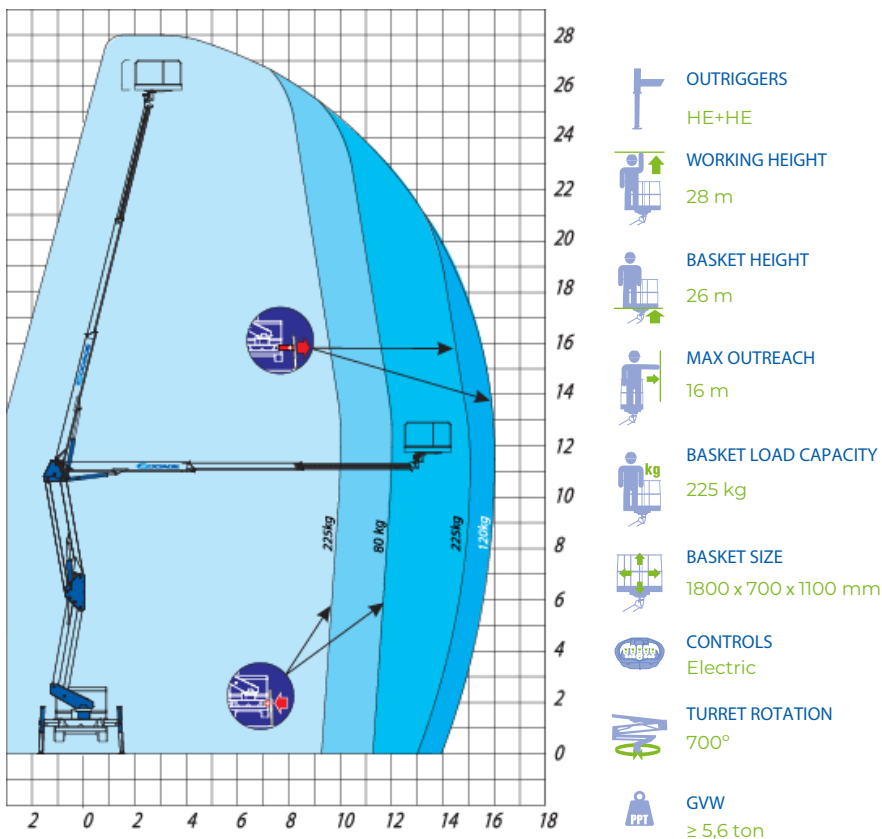

WORKING DIAGRAM



STANDARD ACCESSORIES

DATA SHEET

- Aluminum basket: dimensions 1800 x 700 x 1100 mm
- Hydraulic rotation basket 90° + 90°
- Rotation turret 700°
- Multi-zone stabilization (differentiated areas)
- Double work area with stabilization in shape
- Pipes and cables installed inside the boom
- Hydraulic opening of the crossmember
- Vertical stabilizers with extra stroke
- Engine start / stop control from the basket
- Digital hour counter
- 4 plates to stand to the ground
- Socket 230v
- Magnetic roto-lamp on the vehicle cabin
- Cataphoresis
- Tool trunk
- Under-run
- Hydraulic stabilizers (HE+HE)
- Aluminum side-boards

SAFETY DATA

- Emergency and stop button
- Cross check of open stabilizers
- Multi-axial device for visual control of frame stabilization
- Intelligent cabin anti-collision sensor
- Load limiter in the basket
- Moment limiter with double safety and control of correct operation
- Emergency manual pump
- Chassis flatness sensor
- Flanged block valves
- Differentiated filtering hydraulic system with high efficiency filters both on the delivery lines and on the return lines
- Automatic leveling of the basket
- PTO automatic cut-off
- Control from the basket for acoustic signal

